



Water-Cooled Screw-Compressor Liquid Chillers

PRO-DIALOG



www.eurovent-certification.com
www.certiflash.com



Quality and Environment
Management Systems
Approval

30HXC

Nominal cooling capacity 286-1302 kW

The 30HXC units are water-cooled chillers, designed from the ground up to meet the needs of today and tomorrow:

- ozone-friendly HFC-134a refrigerant
- screw compressors
- fits through a standard door with no disassembly required
- mechanically cleanable evaporators and condensers

All units are equipped with Pro-Dialog Plus control to optimise the efficiency of the refrigerant circuit.

Features

- Quality design and construction make the 30HXC unit the preferred choice.
- Non-controlled, ozone-friendly HFC-134a refrigerant. HFC-134a is a proven, non-toxic, non-flammable refrigerant.
- Medium-pressure refrigerant HFC-134a minimises stress on the compressors and ensures their long operating life.
- The 30HXC units are equipped with screw compressors for extremely quiet operation and low-vibration levels.
- The 30HXC units exceed the efficiency level of average industry standards for both full- and part-load operation, saving on operating costs, through lower electrical costs.
- Part of the 30HXC product range is available equipped with the very low temperature option that permits evaporator leaving water temperatures down to -10°C with ethylene glycol or down to -7°C with propylene glycol.
- The 30HXC control is fully automatic. The leaving water temperature is continuously monitored to detect load and flow changes. This combination provides the most precise temperature control available.
- Two independent refrigerant circuits - the second one takes over automatically, when the first one malfunctions, maintaining partial cooling under all circumstances.
- Easy installation - the 30HXC chillers are supplied with a full refrigerant charge, and conveniently located power supply and water inlet and outlet connections.
- Auto-diagnostics - quick display of the machine status.
- Multiple compressor concept for optimised part-load efficiency and minimised starting current.
- Series star/delta starter, limiting the start-up current on 30HXC 080-190 units.
- All units are also available as high condensing temperature and non-reversible heat pump versions (options 150 and 150A). Their application range is the same as for the standard units, on which they are based, but they also allow condenser leaving water temperatures of up to 63°C . Pro-Dialog control offers all the advantages of the standard units, plus control of the leaving condenser water temperature.

Easy installation

- The 30HXC has a compact design that fits through a standard door opening and requires minimal indoor space. The 30HXC is supplied as a complete package for easy installation. There are no extra controls, timers, starters or other items to install.
- 30HXC units have a single power point and one main disconnect/isolator switch for sizes 30HXC 080 to 190, and one power point and one main disconnect/isolator switch per circuit for sizes 30HXC 200 to 375. The hydraulic connections are simple and facilitated by the use of Victaulic connections for the evaporator and condenser.

Simple to service

- Mechanically-cleanable evaporator and condenser
- Twin-screw compressors which require minimum routine service or maintenance.
- Easily accessed suction and discharge pressure and temperature information via a display module.

Pro-Dialog Plus control

Pro-Dialog Plus is an advanced numeric control system that combines intelligence with great operating simplicity.

Pro-Dialog Plus ensures intelligent leaving water temperature control and optimises energy requirements.

- The PID control algorithm with permanent compensation for the difference between the heat exchanger entering and leaving temperature, anticipates load variations, guarantees leaving water temperature stability and prevents unnecessary compressor cycling.
- The long-stroke electronic expansion valves (EXV), together with refrigerant level control via heat exchange in the evaporator, allows a significant energy efficiency improvement at part load conditions, and faultless chiller operation in a wider temperature range.
- Adjustable ramp loading, according to the inertia of the application, avoids load increases that are too fast and too frequent, increasing unit life and limiting power consumption peaks.
- Several capacity loading possibilities ensure improved start-up at low outdoor air temperature, and permit use of one of the refrigerant circuits as a back-up circuit.

Pro-Dialog Plus ensures preventive protection and enhances chiller reliability.

- Equalisation of compressor operating hours
- No capillary tubes or pressostats (except as safety device)
- Pro-Dialog Plus monitors all chiller safety parameters.
- The fault history function and the fault codes facilitate immediate location of faults and in certain cases the conditions causing the alarm. Prognostic and preventive maintenance functions (incorrect water loop, oil filter dirty etc.) permit anticipation of possible problems.

Pro-Dialog Plus operator interface



Pro-Dialog Plus offers extended communications capabilities

- Clear and easy-to-understand operator interface. The LEDs, numeric displays and touch keys are well-positioned on the schematic chiller diagram. The user immediately knows all operating parameters: pressures, temperatures, operating hours, etc.
- The extensive chiller remote control capabilities (wired connection) allow integration into building management systems (see Technical Description)
- RS485 series port for connection to the Carrier Comfort Network (CCN) or any other monitoring system (optional communications interface with open protocol allows transfer of almost 40 parameters).
- Parallel piloting of two units as standard, or of several units with Flotronic System Manager (FSM) and Chiller System Manager (CSM III) options.
- The control permits:
 - Control in master/slave configuration of two units operating in parallel.
 - Programming of operating time schedules (up to 8 periods per week)
 - Programming of operating time schedules for the second set point (up to 8 periods per week)
 - Definition of operating time period with demand limit.
 - Integration of the unit into a building management system (BMS): serial port RS 485.
- Control of the customer's water pump (dual pump with automatic change-over optional).
- Control at the second set point (example: room unoccupied).
- Set point reset as a function of the air temperature or the difference between entering and leaving water temperature.

The 30HXC fits through a standard door opening, minimising installation cost.

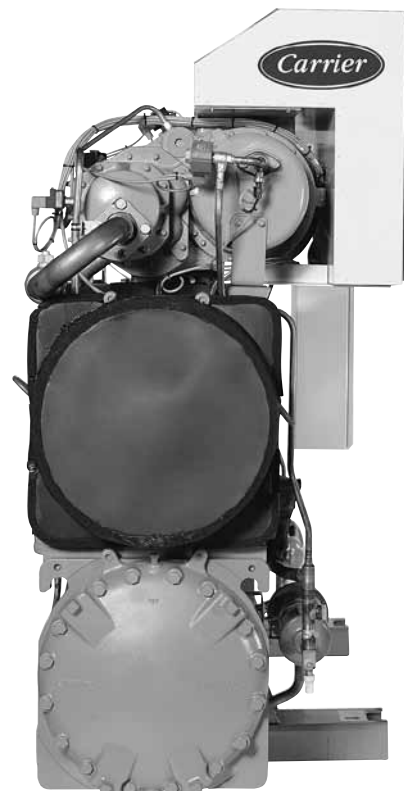

Options

Options	No.	Description	Advantages	Use for 30HXC
Low-temperature brine solution	6	Low-temperature glycol solution production down to -10°C	Covers specific applications such as ice storage and industrial processes	090, 110, 130, 155, 175, 200, 230, 260, 310, 345
IP44C electrical protection level	20	Control box tightness reinforced	Permits unit installation in more severe environments	080-375
Tropicalisation	22	Unit control box suitable for tropical climates	Reduced relative humidity in the control boxes for operation in tropical climates (warm and humid)	080-375
Soft starter	25	Electronic compressor starter	Reduced compressor start-up current	200-375
Unit supplied in two assembled parts	51	Unit supplied in two assembled parts. The unit is equipped with flanges that allow disassembly of the unit on site.	Facilitates installation in plant rooms with limited access	080-375
460-3-60 power supply	60	Power supply of 460 V-3 ph-60 Hz	Permits unit connection to a power network with specific characteristics	080-375
380-3-60 power supply	61	Power supply of 380 V-3 ph-60 Hz	Permits unit connection to a power network with specific characteristics	080-375
Evaporator pump electrical power/control circuit	84	Unit equipped with an electrical power/control circuit for single evaporator pumps	Quick and easy installation	080-375
Dual evaporator pump electrical power/control circuit	84D	Unit equipped with an electrical power/control circuit for dual evaporator pumps	Quick and easy installation	080-375
Condenser pump electrical power/control circuit	84R	Unit equipped with an electrical power/control circuit for single condenser pumps	Quick and easy installation	080-375
Compressor suction valve	92	Valve set for the compressor suction side to isolate it in the refrigerant circuit.	Simplified service and maintenance	080-375
Evaporator with one pass	100C	Evaporator with one pass on the water-side. Evaporator inlet and outlet on opposite sides.	Quick and easy installation. Reduced evaporator pressure losses.	080-375
Condenser with one pass	102C	Condenser with one pass on the water-side. Condenser inlet and outlet on opposite sides.	Quick and easy installation. Reduced condenser pressure losses.	080-375
21 bar evaporator	104	Reinforced evaporator for extension of the maximum water-side service pressure to 21 bar	Covers applications with a high water column (high buildings)	080-375
21 bar condenser	104A	Reinforced condenser for extension of the maximum water-side service pressure to 21 bar	Covers applications with a high water column (high buildings)	080-375
Reversed evaporator water connections	107	Evaporator with reversed water inlet/outlet	Simplification of the water piping	080-375
Reversed condenser water connections	107A	Condenser with reversed water inlet/outlet	Simplification of the water piping	080-375
JBus/ModBus gateway	148B	Two-directional communications board, complies with JBus/ModBus protocol	Easy connection by communication bus to a building management system	080-375
BacNet gateway	148C	Two-directional communications board, complies with BacNet protocol	Easy connection by communication bus to a building management system	080-375
LON gateway	148D	Two-directional communications board, complies with LON protocol	Easy connection by communication bus to a building management system	080-375
High condensing temperature	150	Increased condenser leaving water temperature up to 63°C. Control of the condenser leaving water temperature.	Allows applications with high condensing temperature (for heat reclaim or dry cooler applications)	080-375
High condensing temperature in non-reversible applications	150A	Operation in heat pump mode only with condenser leaving water temperature up to 63°C.	Allows applications with high condensing temperature (for heat reclaim or dry cooler applications)	080-375
Control for low condensing temperature systems	152	Output signal (0-10 V) to control the condenser water inlet valve	Used for applications with cold water at condenser inlet (well water). In this case the valve controls the water entering temp. to maintain an acceptable condensing pressure.	080-375
RS 485 communication interface with open protocol	155	Additional RS 485 communication board	Communication via CCN protocol	080-375
Dual discharge valve installed with three-way valve	194	Three-way valve upstream of the discharge valves on the evaporator and the oil separator	Valve change and inspection facilitated without refrigerant loss. Complies with European standard EN 378/BGVD4.	080-190
Code compliance for Switzerland in addition to PED code	197	Additional tests on the water heat exchangers. Additional supply of PED documents, supplementary certificates and test certificates.	Conformance with Swiss regulations in addition to the PED code	080-375
Russian code compliance	199	GOST certification	Conformance with Russian regulations (GOST)	080-375
Water connection kit for welded evaporator connections	266	Victaulic piping connections with welded joints.	Easy installation	080-375
Water connection kit for welded condenser connections	267	Victaulic piping connections with welded joints.	Easy installation	080-375
Water connection kit for flanged evaporator connections	268	Victaulic piping connections with flanged joints.	Easy installation	080-375
Water connection kit for flanged condenser connections	269	Victaulic piping connections with flanged joints.	Easy installation	080-375

Physical data

30HXC standard unit		080	090	100	110	120	130	140	155	175	190	200	230	260	285	310	345	375	
Air conditioning application as per EN14511-3:2011*																			
Nominal cooling capacity	kW	287	312	349	375	413	450	510	542	599	652	701	814	899	986	1109	1207	1302	
EER	kW/kW	5.04	4.80	4.85	4.57	4.86	4.69	4.72	4.55	4.68	4.72	4.74	4.73	4.45	4.76	4.76	4.55	4.65	
Eurovent class, cooling	-	B	B	B	C	B	B	B	C	B	B	B	B	C	B	B	C	B	
ESEER	kW/kW	5.56	5.41	5.31	5.28	5.23	5.21	5.17	4.85	5.03	4.97	5.08	5.06	5.01	5.11	5.49	5.39	5.34	
Air conditioning application**																			
Nominal cooling capacity	kW	288	314	350	376	414	452	512	545	602	655	704	817	902	991	1113	1212	1308	
EER	kW/kW	5.24	4.98	5.07	4.82	5.11	4.97	4.97	4.78	4.89	4.96	4.96	4.92	4.65	5.01	4.97	4.77	4.90	
ESEER	-	6.20	6.11	5.97	5.94	5.85	5.92	5.84	5.48	5.61	5.59	5.71	5.54	5.55	5.75	6.19	6.12	6.15	
30HXC unit with option 150																			
Air conditioning application as per EN14511-3:2011*																			
Nominal cooling capacity	kW	286	313	345	379	410	460	505	543	583	641	727	800	875	965	1087	1166	1285	
EER	kW/kW	4.47	4.35	4.37	4.36	4.46	4.34	4.28	4.11	4.08	4.08	4.35	4.21	4.03	4.04	4.13	4.03	4.04	
Eurovent class, cooling	-	C	C	C	C	C	C	C	D	D	D	C	D	D	D	D	D	D	
Air conditioning application**																			
Nominal cooling capacity	kW	287	315	347	381	412	462	507	545	585	644	730	803	878	970	1092	1170	1290	
EER	kW/kW	4.63	4.57	4.57	4.54	4.68	4.57	4.49	4.33	4.24	4.29	4.56	4.36	4.18	4.22	4.32	4.21	4.24	
Heating application as per EN14511-3:2011**																			
Heating capacity	kW	327	359	394	434	468	530	583	634	683	781	834	929	1026	1178	1269	1369	1570	
COP	kW/kW	4.30	4.23	4.20	4.22	4.34	4.24	4.25	4.12	4.12	4.13	4.23	4.20	4.07	4.09	4.13	4.09	4.11	
Eurovent class, heating	-	C	D	D	D	C	D	C	D	D	D	D	D	D	D	D	D	D	
Heating application***																			
Heating capacity	kW	326	358	393	433	466	528	580	631	681	778	831	927	1023	1174	1264	1364	1562	
COP	kW/kW	4.52	4.48	4.47	4.46	4.62	4.51	4.50	4.36	4.34	4.42	4.51	4.41	4.28	4.36	4.36	4.32	4.39	
30HXC, all units																			
Operating weight****	kg	2274	2279	2302	2343	2615	2617	2702	2712	3083	3179	3873	4602	4656	4776	5477	5553	5721	
Sound levels****																			
Sound power level	dB(A)	94	94	94	94	94	97	98	100	101	101	99	101	102	102	103	104	104	
Sound pressure level at 1 m	dB(A)	77	77	77	77	76	79	80	82	83	83	80	82	83	83	84	85	85	
Dimensions, standard unit																			
Depth	mm	2558	2558	2558	2565	3275	3275	3275	3275	3275	3903	3924	3924	3924	4533	4533	4533		
Length	mm	980	980	980	980	980	980	980	980	980	1015	1015	1015	1015	1015	1015	1015		
Height	mm	1800	1800	1800	1850	1816	1816	1816	1816	1940	1940	1980	2060	2060	2060	2112	2112	2112	
Compressor																			
06 N semi-hermetic twin-screw compressor																			
Circuit A		1	1	1	1	1	1	1	1	1	1	2	2	2	2	2	2	2	
Circuit B		1	1	1	1	1	1	1	1	1	1	1	1	1	1	2	2	2	
Refrigerant***																			
HFC-134a																			
Circuit A	kg	33	33	32	31	49	51	48	54	54	70	92	115	117	132	109	96	119	
Circuit B	kg	34	34	30	35	52	47	48	57	50	70	68	63	75	80	106	109	137	
Control type																			
Pro-Dialog Plus																			
No. of capacity stages		6	6	6	6	6	6	6	6	6	8	8	8	8	10	10	10		
Minimum capacity	%	19	19	21	19	21	19	17	19	21	21	14	14	14	14	10	10	10	
Evaporator																			
Shell-and tube evaporator with internally finned copper tubes																			
Net water volume	l	50	50	58	69	65	65	75	75	88	88	126	155	170	170	191	208	208	
Water connection		Victaulic connections																	
Inlet and outlet	in	4	4	4	5	5	5	5	5	5	5	6	6	6	6	8	8	8	
Water drain and air purge (NPT)	in	3/8																	
Max. water-side service pressure	kPa	1000	1000	1000	1000	1000	1000	1000	1000	1000	1000	1000	1000	1000	1000	1000	1000	1000	
Condenser																			
Shell-and tube condenser with internally finned copper tubes																			
Net water volume	l	48	48	48	78	78	90	90	108	108	141	190	190	190	255	255	255		
Water connection		Victaulic connectionsC																	
Inlet and outlet	in	5	5	5	5	5	5	5	5	6	6	6	8	8	8	8	8	8	
Water drain and air purge (NPT)	in	3/8																	
Max. water-side operating pressure	kPa	1000	1000	1000	1000	1000	1000	1000	1000	1000	1000	1000	1000	1000	1000	1000	1000	1000	

* Eurovent-certified performances in accordance with standard EN14511-3:2011.

** Gross performances, not in accordance with EN14511-3:2011. These performances do not take into account the correction for the proportional heating capacity and power input generated by the water pump to overcome the internal pressure drop in the heat exchanger.

Conditions in cooling mode: evaporator-condenser entering/leaving water temperature 12°C/7°C, condenser entering/leaving water temperature 30°C/35°C, evaporator fouling factor = 0 m² K/W. Conditions in heating mode: evaporator entering/leaving water temperature 10°C/7°C, condenser entering/leaving water temperature 40°C/45°C, evaporator fouling factor = 0 m² K/W.

*** Weights are guidelines only. The refrigerant charge is given on the unit nameplate.

**** 10⁻¹² W in accordance with ISO 9614-1- in a free field
The sound levels only apply for units without options.

Electrical data

30HXC		080	090	100	110	120	130	140	155	175	190	200	230	260	285	310	345	375	
Power circuit																			
Nominal power supply (Un)*	V-ph-Hz	400-3-50																	
Voltage range	V	360-440																	
Control circuit supply		The control circuit is supplied via the factory-installed transformer																	
Nominal operating power input*	kW	59	67	74	84	88	99	112	122	133	141	154	177	206	216	243	278	296	
Nominal operating current*	A	101	115	127	143	149	168	190	207	226	234	255	294	337	354	399	448	477	
Max. operating power input**	kW	87	97	108	119	131	144	161	175	192	192	212	223	257	288	318	350	384	424
Circuit A	kW	-	-	-	-	-	-	-	-	-	-	144	161	192	212	175	192	212	
Circuit B	kW	-	-	-	-	-	-	-	-	-	-	79	96	96	106	175	192	212	
Max. operating current (Un-10%***)	A	158	176	195	215	235	259	289	314	344	379	401	461	517	568	628	688	758	
Circuit A	A	-	-	-	-	-	-	-	-	-	-	259	289	344	379	314	344	379	
Circuit B	A	-	-	-	-	-	-	-	-	-	-	142	172	172	189	314	344	379	
Max. operating current (Un)***	A	143	160	177	195	213	236	263	285	312	344	365	419	468	516	570	624	688	
Circuit A	A	-	-	-	-	-	-	-	-	-	-	236	263	312	344	285	312	344	
Circuit B	A	-	-	-	-	-	-	-	-	-	-	129	156	156	172	285	312	344	
Max. start-up current, standard unit (Un)****	A	181	206	223	249	267	298	333	355	382	442	841	978	1027	1200	1129	1184	1373	
Circuit A***	A	-	-	-	-	-	-	-	-	-	-	712	822	871	1028	844	871	1028	
Circuit B***	A	-	-	-	-	-	-	-	-	-	-	605	715	715	856	844	871	1028	
Ratio I max. start-up/I max. unit	A	1.26	1.28	1.26	1.27	1.25	1.26	1.27	1.24	1.22	1.28	2.31	2.33	2.19	2.32	1.98	1.89	1.99	
Ratio I max. start-up/I max. circuit A	A	-	-	-	-	-	-	-	-	-	-	3.02	3.13	2.79	2.99	2.96	2.79	2.99	
Ratio I max. start-up/ I max. circuit B	A	-	-	-	-	-	-	-	-	-	-	4.7	4.58	4.58	4.97	2.96	2.79	2.99	
I max. unit start-up at reduced current (Un)****	A	std	std	std	std	std	std	std	std	std	std	636	683	732	824	834	889	997	
Circuit A	A	std	std	std	std	std	std	std	std	std	std	507	527	576	652	549	576	652	
Circuit B	A	std	std	std	std	std	std	std	std	std	std	330	370	370	385	549	576	652	
Ratio I max. start-up at reduced current/I max. unit	A	std	std	std	std	std	std	std	std	std	std	1.74	1.63	1.56	1.6	1.46	1.42	1.45	
Circuit A	A	std	std	std	std	std	std	std	std	std	std	2.15	2	1.84	1.89	1.93	1.84	1.89	
Circuit B	A	std	std	std	std	std	std	std	std	std	std	2.56	2.37	2.37	2.24	1.93	1.84	1.89	
Three-phase short-circuit holding current	kA	25	25	25	25	25	25	25	25	25	25	NA	NA	NA	NA	NA	NA	NA	
Circuit A	A	-	-	-	-	-	-	-	-	-	-	25	25	25	25	25	25	25	
Circuit B	A	-	-	-	-	-	-	-	-	-	-	15	15	15	15	25	25	25	
Customer stand-by capacity, unit or circuit B for evaporator and condenser water pump connections (a)	kW	8	8	8	11	11	11	15	15	15	15	15	18	18	30	30	30	30	

* Standard Eurovent conditions: evaporator entering/leaving water temperature 12°C/7°C, condenser entering/leaving water temperature 30°C/35°C.
 Nominal operating power input = unit power input (compressors, control) plus capacities corresponding to the evaporator and condenser pressure drops (flow rate x pressure drop/0.3).
 ** Compressor power input at unit operating limits (evaporator entering/leaving water temperature 15°C/10°C, condenser entering/leaving water temperature 45°C/50°C) and 400 V nominal voltage (values given on the unit name plate).
 *** Maximum unit operating current at maximum power input.
 **** Maximum instantaneous start-up current (maximum operating current of the smallest compressor(s) + locked rotor current or reduced start-up current of the largest compressor).
 † Current and capacities not included in the values above.
 NA Not applicable

Notes, electrical data and operating conditions

- 30HXC 080-190 units have a single power connection point; 30HXC 200-375 units have two connection points.
 - The control box includes the following standard features:
 - A main disconnect switch
 - Starter and protection devices for the compressor motor, fans and pump
 - Control devices
 - **Field connections:**
 All connections to the system and the electrical installations must be in full accordance with all applicable codes.
 - The Carrier 30HXC units are designed and built to ensure conformance with local codes. The recommendations of European standard EN 60204-1 (corresponds to IEC 60204-1) (machine safety - electrical machine components - part 1: general regulations) are specifically taken into account, when designing the electrical equipment.
 - **Electrical reserves:**
 Circuit B has disconnect switches and branch sections, designed to supply the evaporator and condenser pump power input.
 - Important:**
 - Generally the recommendations of IEC 60364 are accepted as compliance with the requirements of the installation directives. Conformance with EN 60204-1 is the best means of ensuring compliance with the Machines Directive and paragraph 1.5.1.
 - Annex B of EN 60204-1 describes the electrical characteristics used for the operation of the machines.
 - The operating environment for the 30HXC units is specified below:
 1. Environment* - Environment as classified in IEC 60364 paragraph 3:
 - indoor installation
 - ambient temperature range: +5°C to +40°C, class AA4*
 - altitude: ≤ 2000 m
 - presence of hard solids, class AE2 (no significant dust present)
 - presence of corrosive and polluting substances, class AF1 (negligible)
 2. Power supply frequency variation: ± 2 Hz.
 3. The neutral (N) conductor must not be connected directly to the unit (if necessary use a transformer).
 4. Overcurrent protection of the power supply conductors is not provided with the unit.
 5. The factory-installed disconnect switch(es)/circuit breaker(s) is (are) of a type suitable for power interruption in accordance with EN 60947 (corresponds to IEC 60947-3).
 6. The units are designed for connection to TN networks (IEC 60364). For IT networks the earth connection must not be at the network earth. Provide a local earth, consult competent local organisations to complete the electrical installation.
- Note: If particular aspects of an actual installation do not conform to the conditions described above, or if there are other conditions which should be considered, always contact your local Carrier representative.**
- * The protection level required to conform to this class is IP21B (according to reference document IEC 60529). All 30HXC units are protected to IP23C and fulfil this protection condition.

Part load performances

With the rapid increase in energy costs and the care about environmental impacts of electricity production, power consumption of air conditioning equipment has become an important topic. The energy efficiency of a liquid chiller at full load is rarely representative of the actual performance of the units, as on average a chiller works less than 5% of the time at full load.

The heat load of a building depends on many factors, such as the outside air temperature, the exposure to the sun and its occupation.

Consequently it is preferable to use the average energy efficiency, calculated at several operating points that are representative for the unit utilisation.

IPLV (in accordance with AHRI 550/590)

The IPLV (integrated part load value) allows evaluation of the average energy efficiency based on four operating conditions defined by the AHRI (Air Conditioning, Heating and Refrigeration Institute). The IPLV is the average weighted value of the energy efficiency ratios (EER) at different operating conditions, weighted by the operating time.

ESEER (in accordance with EUROVENT)

The ESEER (European seasonal energy efficiency ratio) permits evaluation of the average energy efficiency at part load, based on four operating conditions defined by Eurovent. The ESEER is the average value of energy efficiency ratios (EER) at different operating conditions, weighted by the operating time.

IPLV (integrated part load value)

Load %	Condenser entering water temperature, °C	Energy efficiency	Operating time, %
100	29.4	EER ₁	1
75	23.9	EER ₂	42
50	18.3	EER ₃	45
25	18.3	EER ₄	12

$IPLV = EER_1 \times 1\% + EER_2 \times 42\% + EER_3 \times 45\% + EER_4 \times 12\%$

Note: Constant leaving water temperature 6.67°C (44°F).

ESEER (European seasonal energy efficiency ratio)

Load %	Condenser entering water temperature, °C	Energy efficiency	Operating time, %
100	30	EER ₁	3
75	26	EER ₂	33
50	22	EER ₃	41
25	18	EER ₄	23

$ESEER = EER_1 \times 3\% + EER_2 \times 33\% + EER_3 \times 41\% + EER_4 \times 23\%$

Note: Constant leaving water temperature 7°C.

30HXC - unité standard	080	090	100	110	120	130	140	155	175	190	200	230	260	285	310	345	375	
ESEER	kW/kW	5.56	5.41	5.31	5.28	5.23	5.21	5.17	4.85	5.03	4.97	5.08	5.06	5.01	5.11	5.49	5.39	5.34

ESEER Calculations according to standard performances (in accordance with EN14511-3:2011) and certified by Eurovent.

Sound spectrum

30HXC - standard unit and unit with high condensing temperatures (option 150*)

	Octave bands, Hz	Sound power levels							
		125	250	500	1k	2k	4k		
080	dB	79	84	89	88	90	84	dB(A)	94
090	dB	79	84	89	88	90	84	dB(A)	94
100	dB	79	84	89	88	90	84	dB(A)	94
110	dB	79	84	89	88	90	84	dB(A)	94
120	dB	79	84	89	88	90	84	dB(A)	94
130	dB	79	84	96	92	90	84	dB(A)	97
140	dB	79	84	89	93	94	87	dB(A)	98
155	dB	79	84	96	93	94	91	dB(A)	100
175	dB	79	84	83	96	97	91	dB(A)	101
190	dB	79	84	83	96	97	91	dB(A)	101
200	dB	79	84	98	94	90	84	dB(A)	99
230	dB	79	84	89	96	97	91	dB(A)	101
260	dB	80	85	84	97	98	92	dB(A)	102
285	dB	80	85	84	97	98	92	dB(A)	102
310	dB	81	87	99	96	97	94	dB(A)	103
345	dB	82	87	86	99	100	94	dB(A)	104
375	dB	82	87	86	99	100	94	dB(A)	104

* Option 150: unit with high condensing temperatures

Operating limits, standard units

Condenser water flow rates

30HXC	Minimum flow rate, l/s*		Maximum flow rate, l/s**
	Open loop	Closed loop	
080-110	2.3	7	28.2
120-130	3.1	9.3	37.1
140-155	3.7	11.1	44.5
175-190	4.3	13	51.9
200	4.9	14.8	59.2
230-285	6.7	20.1	80.4
310-375	8	24	95.9

* Based on a velocity of 0.3 m/s in a closed loop and 0.9 m/s in an open loop.
 ** Based on a water velocity of 3.6 m/s.

Evaporator water flow rates

30HXC	Minimum flow rate, l/s	Maximum flow rate, l/s*
080-090	5.2	20.8
100	6.5	25.9
110	7.4	29.6
120-130	8.3	33.4
140-155	9.4	37.8
175-190	11.5	45.9
200	14.1	56.3
230	16.3	65.2
260-285	18.3	73.4
310	20.9	83.7
345-375	23	91.9

* The maximum flow rate corresponds to a pressure drop of 100 kPa.

Operating range, standard units

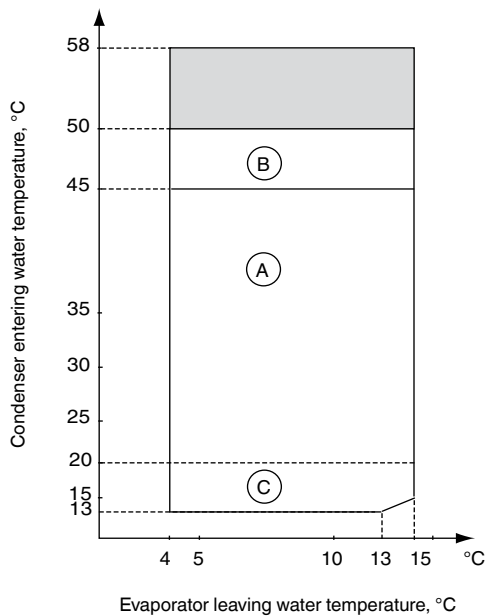

Notes:

1. Evaporator and condenser $\Delta T = 5 K$
 2. For start-up at full load with a condenser water entering temperature below 20°C, a three-way valve must be used to maintain the correct condensing temperature.
 3. Maximum condenser water leaving temperature 50°C (at full load).
 4. For low evaporator leaving water temperatures $<+4^{\circ}C$ and $>-10^{\circ}C$ please order option 6.
- A Standard unit operating at full load.
 B Standard unit operating at reduced load.
 C Units operating with head pressure control with analogue water control valve.
 For transient operating modes (start-up and part load) the unit can operate down to a condenser entering water temperature of 13°C.

Additional operating range for high condensing temperature units and non-reversible heat pumps.

Dimensions/clearances

30HXC 080-190

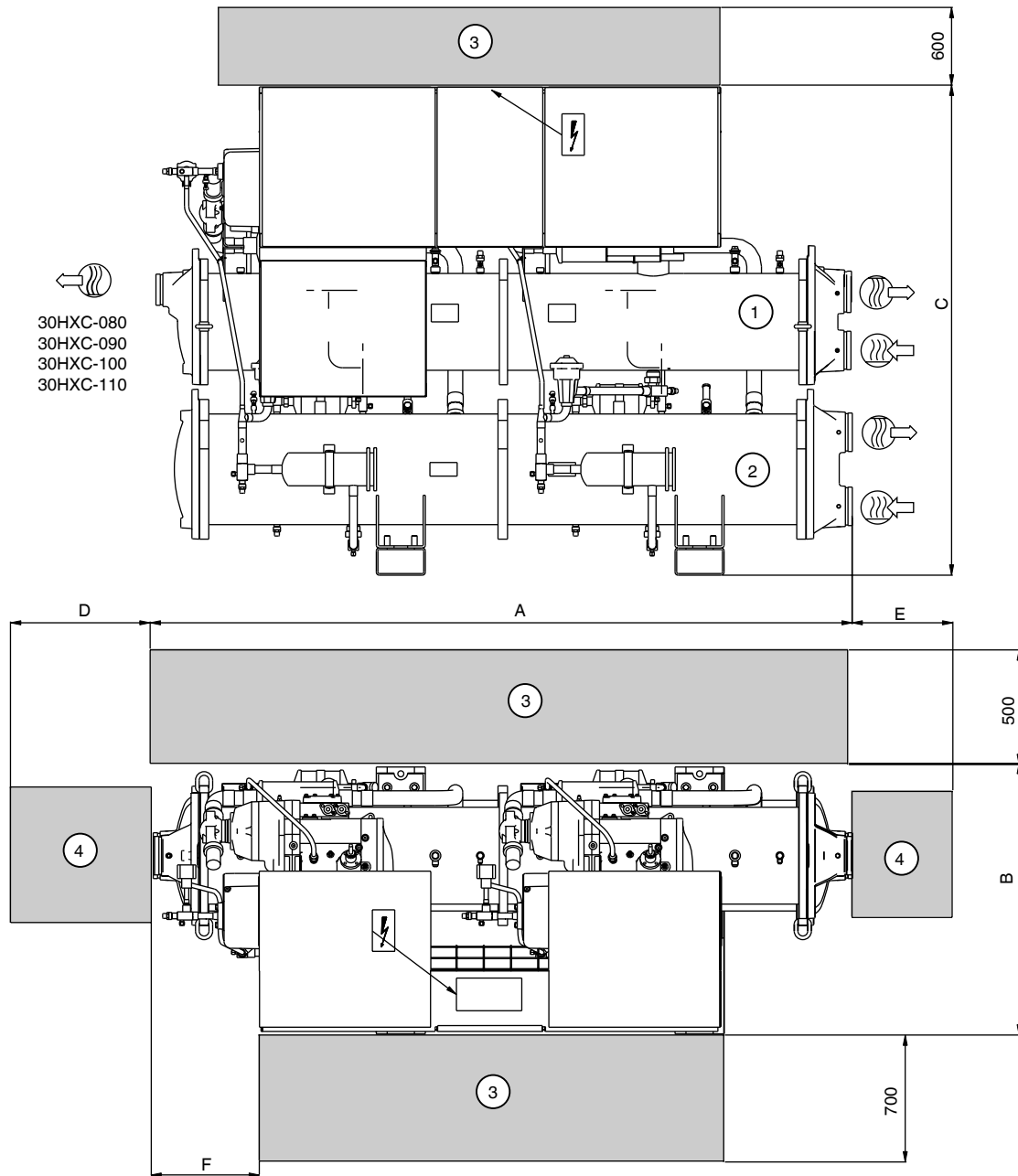

30HXC-080
30HXC-090
30HXC-100
30HXC-110

Legend

All dimensions are given in mm.

- ① Evaporator
- ② Condenser
- ③ Required clearances for maintenance
- ④ Recommended space for tube removal (clearances D and E can be either on the right or the left-hand side).

Water outlet

Water inlet

Power supply connection

Notes:

Non-certified drawings.

Refer to the certified dimensional drawings supplied with the unit or available on request, when designing an installation.

For the location of fixing points, weight distribution and coordinates of the centre of gravity refer to the certified dimensional drawings.

30HXC	A	B	C	D	E	F
080-100	2558	980	1800	2200	1000	385
110	2565	980	1850	2200	1000	385
120-155	3275	980	1816	2990	1000	689
175-190	3275	980	1940	2990	1000	689

Cooling capacities in accordance with EN14511-3 : 2011

30HXC standard units

30HXC	LWT °C	Condenser entering water temperature, °C															
		25				30				35				40			
		Qc kW	EER kW/kW	q l/s	Δp kPa	Qc kW	EER kW/kW	q l/s	Δp kPa	Qc kW	EER kW/kW	q l/s	Δp kPa	Qc kW	EER kW/kW	q l/s	Δp kPa
080	5	281	5.51	13.5	54	267	4.77	12.8	49	252	4.06	12.1	44	237	3.43	11.3	39
090		305	5.17	14.7	63	291	4.55	14	58	275	3.87	13.2	52	258	3.23	12.4	46
100		341	5.25	16.4	58	324	4.56	15.6	53	307	3.89	14.7	47	289	3.28	13.9	42
110		366	5.01	17.5	50	349	4.36	16.7	45	331	3.72	15.9	41	312	3.12	14.9	37
120		402	5.29	19.3	45	384	4.63	18.4	41	364	3.91	17.5	37	344	3.31	16.5	33
130		439	5.16	21.1	51	419	4.46	20.1	47	398	3.79	19.1	42	376	3.16	18	38
140		497	5.12	23.8	50	475	4.48	22.8	45	450	3.81	21.6	41	425	3.22	20.4	37
155		528	4.93	25.3	55	504	4.27	24.2	51	479	3.66	23	46	452	3.07	21.7	41
175		583	5.03	28	54	556	4.38	26.7	49	528	3.77	25.3	44	499	3.18	23.9	40
190		628	5.06	30.2	60	612	4.50	29.3	57	593	3.93	28.5	54	573	3.37	27.5	51
200		683	5.17	32.7	55	651	4.46	31.3	51	618	3.77	29.7	46	584	3.16	28	41
230		793	5.12	38	53	756	4.45	36.3	48	717	3.81	34.4	43	676	3.20	32.4	39
260		875	4.81	42	54	835	4.20	40	49	792	3.60	38	44	746	3.02	35.8	39
285		952	5.15	45.7	61	925	4.53	44.4	58	897	3.95	43	54	865	3.41	41.5	51
310		1079	5.16	52	58	1030	4.48	49.4	53	978	3.81	46.9	48	923	3.19	44.2	43
345		1175	4.92	56	58	1121	4.28	54	53	1063	3.68	51	48	1002	3.10	48	43
375		1256	5.00	60	66	1221	4.42	59	62	1184	3.87	57	59	1143	3.32	55	55
080	7	301	5.79	14.5	62	287	5.04	13.8	57	271	4.30	13	51	255	3.64	12.2	45
090		328	5.47	15.7	73	312	4.80	15	66	296	4.11	14.2	60	279	3.49	13.4	53
100		366	5.55	17.6	66	349	4.85	16.7	60	331	4.14	15.9	54	311	3.49	14.9	49
110		393	5.31	18.9	57	375	4.57	18	52	356	3.96	17.1	47	336	3.33	16.1	42
120		432	5.61	20.7	51	413	4.86	19.8	47	392	4.17	18.8	43	371	3.50	17.8	38
130		471	5.48	22.6	58	450	4.69	21.6	54	428	4.00	20.6	49	405	3.38	19.4	44
140		534	5.39	25.6	57	510	4.72	24.5	52	485	4.08	23.3	47	459	3.45	22	42
155		567	5.25	27.2	63	542	4.55	26	58	516	3.91	24.8	53	488	3.28	23.4	47
175		627	5.36	30.1	62	599	4.68	28.7	56	570	4.01	27.3	51	538	3.41	25.8	46
190		669	5.31	32.1	68	652	4.72	31.3	65	632	4.13	30.3	61	611	3.57	29.3	57
200		733	5.47	35.2	63	701	4.74	33.6	58	666	4.01	32	53	630	3.37	30.2	47
230		853	5.43	40.9	60	814	4.73	39.1	55	773	4.07	37.1	50	730	3.43	35	45
260		941	5.11	45.2	62	899	4.45	43.1	56	853	3.83	40.9	51	806	3.24	38.6	46
285		1014	5.39	48.7	69	986	4.76	47.3	65	956	4.16	45.9	61	923	3.58	44.3	57
310		1160	5.50	56	66	1109	4.76	53	61	1054	4.07	51	55	996	3.42	47.8	50
345		1264	5.20	61	67	1207	4.55	58	61	1146	3.91	55	56	1083	3.31	52	50
375		1338	5.25	64	74	1302	4.65	63	71	1263	4.06	61	66	1220	3.51	59	62
080	10	332	6.15	16	75	317	5.47	15.2	68	301	4.70	14.4	62	283	3.99	13.6	55
090		361	5.92	17.4	88	344	5.13	16.6	80	327	4.42	15.7	72	309	3.77	14.8	65
100		403	5.93	19.4	80	385	5.20	18.5	73	366	4.46	17.6	66	345	3.79	16.6	59
110		434	5.64	20.8	69	414	4.93	19.9	63	393	4.23	18.9	57	371	3.60	17.8	51
120		476	5.95	22.9	62	456	5.24	21.9	57	434	4.47	20.8	52	411	3.81	19.7	47
130		519	5.83	24.9	70	497	5.07	23.9	65	473	4.34	22.7	59	449	3.68	21.5	53
140		589	5.83	28.3	69	564	5.08	27.1	63	537	4.40	25.8	58	509	3.74	24.4	52
155		626	5.64	30.1	77	599	4.91	28.8	70	571	4.23	27.4	64	542	3.59	26	58
175		692	5.77	33.3	75	663	5.06	31.8	69	631	4.38	30.3	62	598	3.71	28.7	56
190		731	5.67	35.1	81	712	5.05	34.2	77	691	4.43	33.2	73	668	3.84	32.1	68
200		810	5.91	38.9	77	775	5.13	37.2	70	738	4.37	35.4	64	699	3.68	33.5	58
230		942	5.85	45.2	73	901	5.12	43.2	67	857	4.42	41.1	61	812	3.74	38.9	55
260		1040	5.50	49.9	75	994	4.83	47.7	68	946	4.17	45.4	62	895	3.54	42.9	56
285		1107	5.74	53	81	1078	5.08	52	77	1045	4.45	50	73	1010	3.84	48.5	68
310		1282	5.94	62	80	1227	5.16	59	74	1168	4.44	56	67	1107	3.74	53	61
345		1397	5.61	67	81	1336	4.93	64	74	1271	4.27	61	68	1203	3.61	58	61
375		1462	5.58	70	88	1423	4.96	68	84	1381	4.36	66	79	1335	3.76	64	74
080	12	353	6.54	17	84	337	5.71	16.2	77	320	4.92	15.4	70	302	4.19	14.5	62
090		383	6.08	18.4	98	366	5.38	17.6	90	348	4.64	16.7	81	329	3.96	15.8	73
100		428	6.20	20.6	90	409	5.38	19.7	82	389	4.69	18.7	75	368	3.96	17.7	67
110		461	5.91	22.2	78	440	5.12	21.1	71	418	4.45	20.1	64	395	3.76	19	58
120		506	6.25	24.3	69	485	5.45	23.3	64	462	4.71	22.2	58	438	3.98	21	53
130		550	6.11	26.5	79	528	5.33	25.3	73	504	4.58	24.2	66	478	3.85	23	60
140		625	6.07	30	77	599	5.30	28.8	71	572	4.61	27.5	65	543	3.93	26	59
155		665	5.94	32	86	637	5.18	30.6	79	608	4.47	29.2	72	577	3.77	27.7	65
175		736	6.03	35.4	84	705	5.30	33.9	77	672	4.60	32.3	70	638	3.91	30.6	64
190		772	5.89	37.1	90	752	5.26	36.1	85	730	4.62	35.1	81	706	4.01	33.9	76
200		860	6.19	41.3	86	824	5.35	39.6	79	785	4.59	37.7	72	745	3.88	35.7	65
230		1002	6.15	48.1	82	959	5.39	46	75	913	4.63	43.8	69	866	3.95	41.6	62
260		1106	5.79	53	84	1058	5.06	51	77	1007	4.40	48.4	70	954	3.74	45.8	63
285		1169	5.93	56	90	1138	5.27	55	86	1104	4.64	53	81	1068	4.02	51	76
310		1363	6.22	65	90	1305	5.41	63	83	1244	4.68	60	76	1180	3.96	57	68
345		1485	5.87	71	91	1421	5.17	68	84	1354	4.47	65	76	1284	3.81	62	69
375		1545	5.81	74	98	1504	5.17	72	93	1459	4.53	70	88	1411	3.93	68	82

Legend

LWT Leaving water temperature, °C
 Qc Cooling capacity, kW
 EER Energy efficiency ratio, kW/kW
 q Evaporator water flow rate, l/s
 Δp Evaporator pressure drop, kPa

Application data

Standard units, refrigerant: R-134a
 Evaporator and condenser entering/leaving water temperature difference: 5 K
 Evaporator and condenser fluid: chilled water
 Fouling factor: 0 m² K/W

Performances in accordance with EN14511-3:2011.

Cooling capacities

30HXC standard units

30HXC	LWT °C	Condenser entering water temperature, °C															
		25				30				35				40			
		Qc kW	EER kW/kW	q l/s	Δp kPa	Qc kW	EER kW/kW	q l/s	Δp kPa	Qc kW	EER kW/kW	q l/s	Δp kPa	Qc kW	EER kW/kW	q l/s	Δp kPa
080	5	282	5.73	13.5	54	268	4.96	12.8	49	253	4.22	12.1	44	237	3.49	11.3	39
090	5	307	5.48	14.7	63	292	4.71	14	58	276	4.00	13.2	52	259	3.32	12.4	46
100	5	342	5.52	16.4	58	326	4.72	15.6	53	308	4.05	14.7	47	290	3.37	13.9	42
110	5	367	5.24	17.5	50	350	4.55	16.7	45	332	3.86	15.9	41	313	3.23	14.9	37
120	5	404	5.61	19.3	45	385	4.81	18.4	41	366	4.07	17.5	37	345	3.38	16.5	33
130	5	441	5.44	21.1	51	421	4.68	20.1	47	400	3.92	19.1	42	377	3.25	18	38
140	5	499	5.42	23.8	50	476	4.67	22.8	45	452	3.96	21.6	41	426	3.33	20.4	37
155	5	530	5.25	25.3	55	506	4.48	24.2	51	481	3.82	23	46	454	3.17	21.7	41
175	5	585	5.27	28	54	559	4.58	26.7	49	530	3.90	25.3	44	500	3.27	23.9	40
190	5	631	5.35	30.2	60	614	4.69	29.3	57	595	4.08	28.5	54	575	3.48	27.5	51
200	5	685	5.44	32.7	55	654	4.64	31.3	51	621	3.91	29.7	46	585	3.23	28	41
230	5	796	5.34	38	53	759	4.60	36.3	48	720	3.91	34.4	43	678	3.28	32.4	39
260	5	879	5.02	42	54	838	4.34	40	49	794	3.69	38	44	749	3.11	35.8	39
285	5	956	5.40	45.7	61	929	4.72	44.4	58	900	4.11	43	54	868	3.50	41.5	51
310	5	1084	5.42	52	58	1034	4.66	49.4	53	981	3.94	46.9	48	925	3.28	44.2	43
345	5	1180	5.18	56	58	1125	4.46	54	53	1067	3.81	51	48	1005	3.19	48	43
375	5	1261	5.28	60	66	1227	4.65	59	62	1189	4.03	57	59	1147	3.44	55	55
080	7	303	6.10	14.5	62	288	5.24	13.8	57	273	4.48	13	51	256	3.76	12.2	45
090	7	329	5.77	15.7	73	314	4.98	15	66	297	4.24	14.2	60	280	3.59	13.4	53
100	7	368	5.84	17.6	66	350	5.07	16.7	60	332	4.31	15.9	54	313	3.60	14.9	49
110	7	395	5.56	18.9	57	376	4.82	18	52	357	4.10	17.1	47	337	3.44	16.1	42
120	7	434	5.95	20.7	51	414	5.11	19.8	47	394	4.33	18.8	43	372	3.61	17.8	38
130	7	473	5.77	22.6	58	452	4.97	21.6	54	430	4.17	20.6	49	407	3.51	19.4	44
140	7	536	5.76	25.6	57	512	4.97	24.5	52	487	4.23	23.3	47	460	3.57	22	42
155	7	570	5.59	27.2	63	545	4.78	26	58	518	4.08	24.8	53	490	3.40	23.4	47
175	7	630	5.63	30.1	62	602	4.89	28.7	56	572	4.18	27.3	51	540	3.51	25.8	46
190	7	673	5.66	32.1	68	655	4.96	31.3	65	635	4.32	30.3	61	614	3.70	29.3	57
200	7	737	5.80	35.2	63	704	4.96	33.6	58	669	4.18	32	53	632	3.47	30.2	47
230	7	856	5.71	40.9	60	817	4.92	39.1	55	776	4.19	37.1	50	733	3.52	35	45
260	7	945	5.37	45.2	62	902	4.65	43.1	56	857	3.97	40.9	51	809	3.33	38.6	46
285	7	1019	5.69	48.7	69	991	5.01	47.3	65	960	4.34	45.9	61	927	3.71	44.3	57
310	7	1166	5.80	56	66	1113	4.97	53	61	1058	4.23	51	55	1000	3.53	47.8	50
345	7	1269	5.52	61	67	1212	4.77	58	61	1151	4.08	55	56	1086	3.43	52	50
375	7	1345	5.58	64	74	1308	4.90	63	71	1268	4.27	61	66	1225	3.65	59	62
080	10	334	6.68	16	75	319	5.70	15.2	68	302	4.87	14.4	62	285	4.13	13.6	55
090	10	363	6.37	17.4	88	347	5.51	16.6	80	329	4.70	15.7	72	310	3.92	14.8	65
100	10	405	6.33	19.4	80	387	5.45	18.5	73	367	4.71	17.6	66	347	3.94	16.6	59
110	10	436	6.06	20.8	69	416	5.20	19.9	63	395	4.44	18.9	57	373	3.73	17.8	51
120	10	478	6.37	22.9	62	458	5.52	21.9	57	436	4.74	20.8	52	413	3.97	19.7	47
130	10	521	6.28	24.9	70	499	5.42	23.9	65	476	4.58	22.7	59	451	3.82	21.5	53
140	10	592	6.23	28.3	69	566	5.39	27.1	63	540	4.66	25.8	58	511	3.90	24.4	52
155	10	629	6.11	30.1	77	602	5.23	28.8	70	574	4.48	27.4	64	544	3.75	26	58
175	10	696	6.16	33.3	75	666	5.37	31.8	69	634	4.59	30.3	62	601	3.88	28.7	56
190	10	735	6.13	35.1	81	716	5.38	34.2	77	694	4.69	33.2	73	672	4.02	32.1	68
200	10	814	6.36	38.9	77	778	5.44	37.2	70	741	4.60	35.4	64	702	3.84	33.5	58
230	10	947	6.23	45.2	73	905	5.39	43.2	67	861	4.60	41.1	61	815	3.88	38.9	55
260	10	1045	5.87	49.9	75	999	5.07	47.7	68	950	4.36	45.4	62	899	3.67	42.9	56
285	10	1113	6.12	53	81	1083	5.39	52	77	1050	4.69	50	73	1015	4.01	48.5	68
310	10	1288	6.34	62	80	1232	5.48	59	74	1173	4.65	56	67	1111	3.90	53	61
345	10	1404	6.03	67	81	1342	5.22	64	74	1277	4.48	61	68	1208	3.78	58	61
375	10	1470	6.02	70	88	1431	5.30	68	84	1388	4.61	66	79	1341	3.96	64	74
080	12	355	6.96	17	84	339	6.05	16.2	77	322	5.19	15.4	70	303	4.39	14.5	62
090	12	386	6.66	18.4	98	368	5.75	17.6	90	350	4.93	16.7	81	331	4.14	15.8	73
100	12	431	6.63	20.6	90	411	5.79	19.7	82	391	4.95	18.7	75	370	4.16	17.7	67
110	12	464	6.36	22.2	78	442	5.46	21.1	71	420	4.67	20.1	64	397	3.93	19	58
120	12	508	6.68	24.3	69	487	5.80	23.3	64	464	4.99	22.2	58	440	4.19	21	53
130	12	554	6.67	26.5	79	530	5.70	25.3	73	506	4.87	24.2	66	480	4.07	23	60
140	12	629	6.55	30	77	602	5.68	28.8	71	575	4.91	27.5	65	545	4.13	26	59
155	12	669	6.43	32	86	641	5.57	30.6	79	611	4.74	29.2	72	580	3.97	27.7	65
175	12	740	6.49	35.4	84	709	5.67	33.9	77	676	4.86	32.3	70	641	4.11	30.6	64
190	12	776	6.41	37.1	90	756	5.64	36.1	85	734	4.93	35.1	81	710	4.23	33.9	76
200	12	865	6.71	41.3	86	828	5.75	39.6	79	789	4.87	37.7	72	748	4.07	35.7	65
230	12	1007	6.54	48.1	82	963	5.70	46	75	918	4.88	43.8	69	870	4.10	41.6	62
260	12	1112	6.18	53	84	1063	5.37	51	77	1012	4.60	48.4	70	959	3.88	45.8	63
285	12	1176	6.39	56	90	1145	5.64	55	86	1110	4.91	53	81	1073	4.21	51	76
310	12	1370	6.72	65	90	1312	5.78	63	83	1250	4.94	60	76	1186	4.13	57	68
345	12	1493	6.35	71	91	1429	5.52	68	84	1361	4.74	65	76	1290	3.99	62	69
375	12	1554	6.32	74	98	1512	5.56	72	93	1467	4.84	70	88	1419	4.15	68	82

Legend

LWT Leaving water temperature, °C
 Qc Cooling capacity, kW
 EER Energy efficiency ratio, kW/kW
 q Evaporator water flow rate, l/s
 Δp Evaporator pressure drop, kPa

Application data

Standard units, refrigerant: R-134a
 Evaporator and condenser entering/leaving water temperature difference: 5 K
 Evaporator and condenser fluid: chilled water
 Fouling factor: 0 m² K/W

Gross performances, not in accordance with EN14511-3:2011. These performances do not take into account the correction for the proportional heating capacity and power input generated by the water pump to overcome the internal pressure drop in the heat exchanger.